

# BAYLAN

## WATER METERS

### KK-12S

#### Single jet Dry type Water Meter (Hot Water)

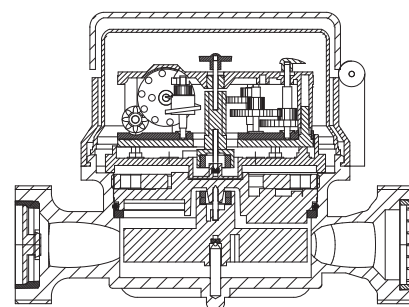

#### GENERAL

- MID Certified
- Single jet design assures very high sensitivity even at low flows
- Plastic upper body with high resistance to pressure and impacts
- Electrostatic painted body made of corrosion resistant brass
- Protection against external magnetic fields
- Wiper on the glass is optional
- Vacuumed mechanism
- Available for optical reading
- 3 years of warranty • Almost no maintenance
- Suitable for cold water up to 90°C
- Service and spare parts available for 10 years
- IP68 Protected
- Environmental Classes

Climatic : -10°C/+55°C | Mechanic: M1/O | Elektromagnetic: E2

•  $Q_2 \leq Q \leq Q_4$  Maximum Permissible Error

Class 2 Water Meters;  $\% \pm 2$  (Water Temp.  $\leq 30^\circ\text{C}$ ),  $\% \pm 3$  (Water Temp.  $> 30^\circ\text{C}$ )

Class 1 Water Meters;  $\% \pm 1$  (Water Temp.  $\leq 30^\circ\text{C}$ ),  $\% \pm 2$  (Water Temp.  $> 30^\circ\text{C}$ )

•  $Q_1 \leq Q < Q_2$  Maximum Permissible Error

Class 2 Water Meters;  $\% \pm 5$  | Class 1 Water Meters;  $\% \pm 3$



#### PERFORMANCE DATA

Overload Flowrate	Q4	m <sup>3</sup> /h	3,125	
Permanent Flowrate	Q3	m <sup>3</sup> /h	2,5	
Transitional Flowrate	Q2	m <sup>3</sup> /h	0,040	0,050
Minimum Flowrate	Q1	m <sup>3</sup> /h	0,025	0,03125
Q3/Q1 (MI-001 OIML R49)	-		$\leq 100$	$\leq 80$
Mounting on the network	-		H	V
Maximum Registration Capacity	m <sup>3</sup>	9999 / 99999 / 99999,99 / 99999,999		
Initial Flow	Qi	l/h	5	
Maximum Working Pressure	bar	16		
Maximum Working Temperature	°C	90		
Pressure Loss Class	bar	0,63		
Smallest Reading Resolution	m <sup>3</sup> /h	0,00005		
Class	-	Class 1/Class 2		
Quantity per package	-	10		
Package dimensions	cm	21x42,5x16		

#### PRESSURE LOSS CURVE

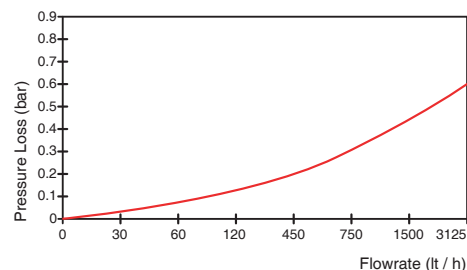

#### PERFORMANCE CURVE

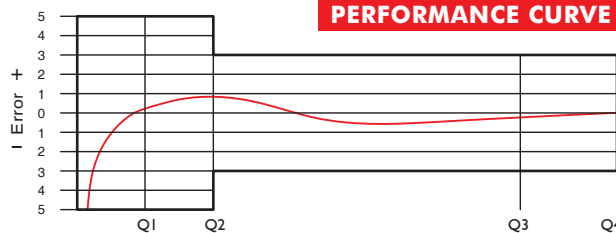

#### DIMENSIONS

Nominal diameter	DN	15	20	mm
Connecting diameter	D	G 3/4	G 1	B
Total overall meter height	H	82	82	mm
Axis height	h	17	17	mm
Length	L	110/115	110/115	mm
Width	B	74,2	74,2	mm
Length with connections	LB	190/195	190/195	mm
Unit weight		0,45	0,56	kg
Package Weight (without connections)		5,47	6,18	kg
Package Weight (with connections)		6,72	8,08	kg

