

BAYLAN

WATER METERS

TK-2 RF

Multi jet Dry type Water Meter



GENERAL

LoRa® & wM-Bus Smart Water Meter

- Compact design; meter and communication module in the same housing
- Integrated LoRa® module-chipset allows both LoRa® and FSK modulation
- Supports LoRaWAN® - Class A Protocol
- Supports Wireless MBUS Protocol
- Selectable Frequency Band EU 863-870 Mhz
- MID Certified • IP68 Protected
- Vacuumed/air-free mechanism suitable for tropical installation conditions
- Electrostatic epoxy painted body made of corrosion-resistant brass alloy
- Multi jet working principle assures a long service time
- Suitable for potable water and cold water up to 50°C
- Low pressure loss, high sensitivity at initial flow
- Special glass with high resistance to pressure and impact
- Star wheels indicator ready for optical pulse read-out
- 3 years of warranty • Integrated strainer and non-return valve
- Almost no maintenance • Service and spare parts available for 10 years
- Exchangeable 3.6V Lithium Battery • Up to 16 years battery life*
- Environmental Classes

Climatic : -10°C/+55°C | Mechanic: M1/O | Elektromagnetic: E2

- Q2 ≤ Q ≤ Q4 Maximum Permissible Error

Class 2 Water Meters; % ± 2 (Water Temp. ≤ 30°C), % ± 3 (Water Temp. > 30°C)

Class 1 Water Meters; % ± 1 (Water Temp. ≤ 30°C), % ± 2 (Water Temp. > 30°C)

- Q1 ≤ Q < Q2 Maximum Permissible Error

Class 2 Water Meters; % ± 5 | Class 1 Water Meters; % ± 3

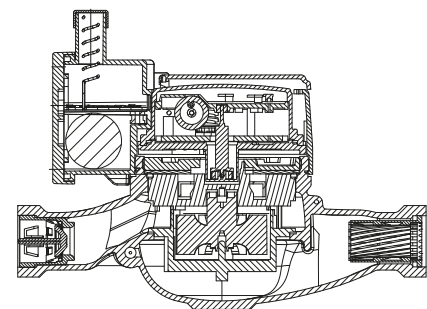

PERFORMANCE DATA

Overload Flowrate	Q4	m ³ /h	5	
Permanent Flowrate	Q3	m ³ /h	4	
Transitional Flowrate	Q2	m ³ /h	0,0256	0,08
Minimum Flowrate	Q1	m ³ /h	0,016	0,05
Q3/Q1 (MI-001 OIML R49)			≤250	≤80
Mounting on the network			H	V
Maximum Registration Capacity			9999 / 99999 / 99999,99 / 99999,999	
Initial Flowrate	Qi	l/h	6	
Maximum Working Pressure		bar	16	
Maximum Working Temperature		°C	50	
Pressure Loss Class		bar	0,63	
Smallest Reading Resolution		m ³	0,00005	
Class			Class 1 / Class 2	

DIMENSIONS

Nominal diameter	DN	20	mm
Connecting diameter	D	G 1	B
Total overall meter height	H	138,2	mm
Axis height	h	31,7	mm
Width	B	85	mm
Length	L	190	mm
Length with connections	LB	270	mm
Unit weight		1,21	kg
Package Weight (without connect)		6,81	kg
Package Weight (with connect)		7,76	kg
Quantity per package		5	pcs
Package dimensions		19x54x23	cm

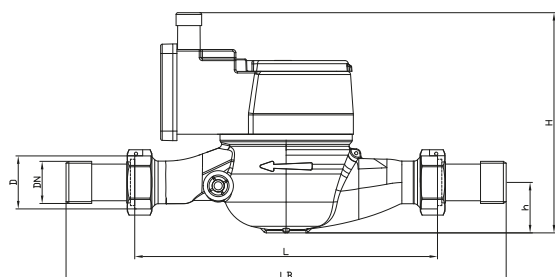
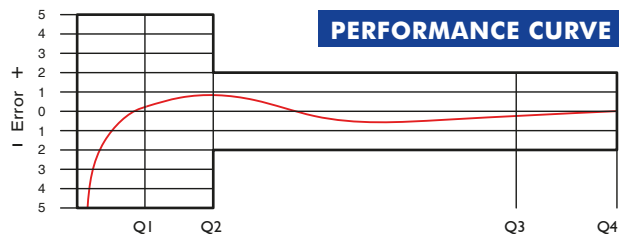
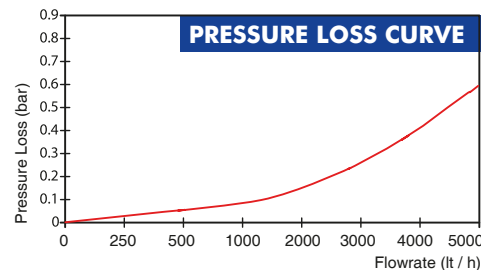

* Standard conditions of use and temperature. Theoretical life, with no guarantee.

"Due to continuous development of our products, we reserve the right to modify our product design or construction without prior notice."