

BAYLAN

WATER METERS

TK-23

Multi jet Dry type Water Meter

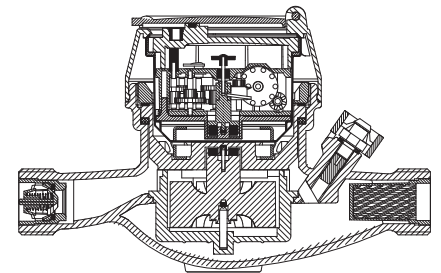

GENERAL

- MID Certified
- Suitable for potable water • 359° rotating dial
- Multi jet working principle assures a long service time
- Low pressure loss, high sensitivity at initial flow
- Vacuumed mechanism • Protection against magnetic effects
- Electrostatic painted body made of corrosion resistant brass
- Protection against external magnetic fields
- For optical reading • Non return valve
- AMR reading features are optional
- 3 years of warranty • Almost no maintenance
- Stainless steel register cup is optional
- Suitable for cold water up to 50°C
- Service and spare parts available for 10 years
- IP68 Protected
- Environmental Classes

Climatic : -10°C/+55°C | Mechanic: M1/O | Elektromagnetic: E2

- $Q2 \leq Q \leq Q4$ Maximum Permissible Error
Class 2 Water Meters; $\% \pm 2$ (Water Temp. $\leq 30^\circ\text{C}$), $\% \pm 3$ (Water Temp. $> 30^\circ\text{C}$)
- $Q1 \leq Q < Q2$ Maximum Permissible Error
Class 1 Water Meters; $\% \pm 1$ (Water Temp. $\leq 30^\circ\text{C}$), $\% \pm 2$ (Water Temp. $> 30^\circ\text{C}$)
- $Q1 \leq Q < Q2$ Maximum Permissible Error
Class 2 Water Meters; $\% \pm 5$ | Class 1 Water Meters; $\% \pm 3$



PERFORMANCE DATA

Overload Flowrate	Q4	m ³ /h	3,125
Permanent Flowrate	Q3	m ³ /h	2,5
Transitional Flowrate	Q2	m ³ /h	0,0200
Minimum Flowrate	Q1	m ³ /h	0,0125
Q3/Q1 (MI-001 OIML R49)	-		≤ 200
Mounting on the network	-		Horizontal
Initial Flow	Qi	l/h	5
Maximum Working Pressure	bar		16
Maximum Working Temperature	°C		50
Pressure Loss Class	bar		0,63
Maximum Registration Capacity	m ³		9999/99999/99999,99/99999,999
Smallest Reading Resolution	m ³ /h		0,00005
Class	-		Class 1 / Class 2
Quantity per package	-		10
Package dimensions	cm		24,5x45x20

DIMENSIONS

Nominal diameter	DN	15	mm
Connecting diameter	D	G 3/4	B
Total overall meter height	H	107	mm
Axis height	h	28	mm
Width	B	77	mm
Length	L	165 170	mm
Length with connections	LB	245 250	mm
Unit weight		0,86	kg
Package Weight (without connect)		9,50	kg
Package Weight (with connect)		11,13	kg

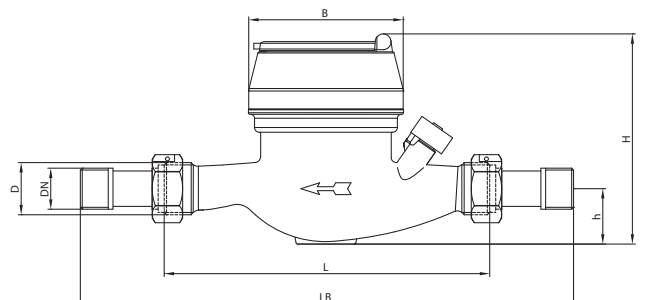
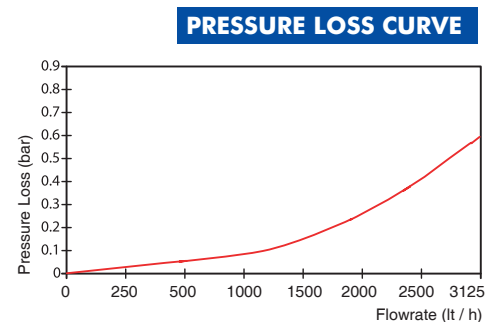
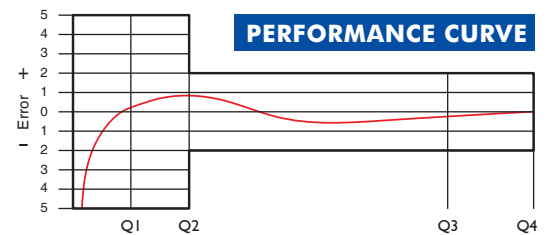

"Due to continuous development of our products, we reserve the right to modify our product design or construction without prior notice."